

銘板表示 (NAME PLATE)

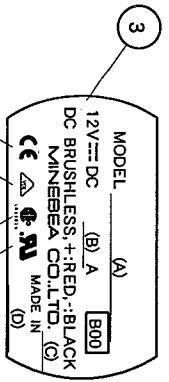

Object Model	(A)	(B)	(C)	(D)
Model Name	3106KL-04W-B30	0.16	Factory ID	Producing Country
	3106KL-04W-B40	0.23	C: JAPAN	JAPAN or CHINA
	3106KL-04W-B50	0.30	7: CHINA	

外觀圖 (OUTLINE)

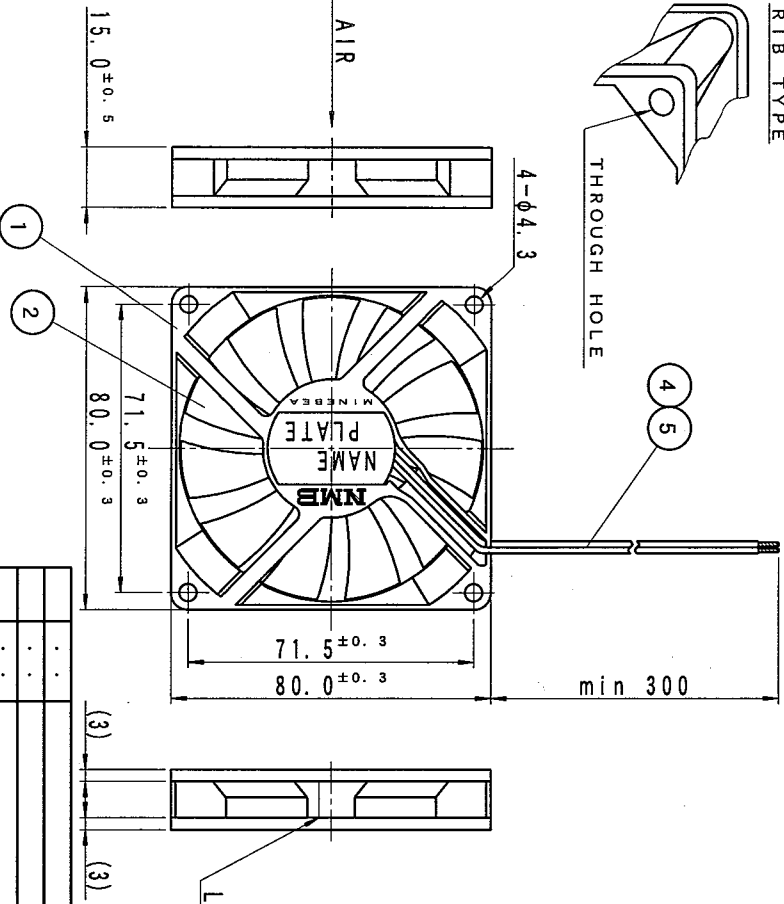

部品構成表 (PART LIST)

品番 ITEM NO.	品名 DESCRIPTION	材質 MATERIAL	個数 QTY	備考 REMARKS
1	ケーシング (CASING)	プラスチック PLASTIC BLACK UL 94V-0	1	
2	インペラー (IMPELLER)	プラスチック PLASTIC BLACK UL 94V-0	1	
3	銘板 (NAME PLATE)		1	
4	リード線 (LEAD WIRE)	UL1007 AWG26	1	赤 (+) (RED)
5	リード線 (LEAD WIRE)	UL1007 AWG26	1	黒 (-) (BLACK)
	軸受 (BEARING)	ボールベアリング (BALL BEARING)	2	

取付穴参考寸法 (PANEL OUT-CUTS)

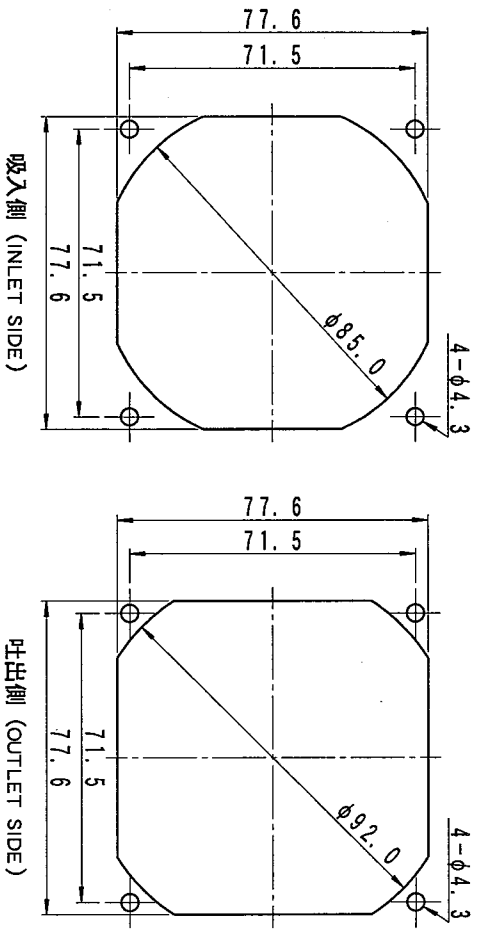

MINEBEA 株式会社 MINEBEA CO.,LTD.		MATERIAL		作成日 DATE		SdP / 08 / 2000	
APPROVED	CHECKED	DRAWN	表面粗度 SURF. ROUGH.	品名 DESCRIPTION	AUTO RESTART TYPE DC BRUSHLESS FAN		
OTK	ICHI	MSO	熱処理 HEAT TREAT	品番 PART NO. (MODEL NO.)	3106KL-04W-BX0-B00		
承認 APPROVED		担当 ENGINEER	表面処理 FINISH	図番 DRAWING NO.	3106KL-04W-BX0-B00		
理由 REASON		ECN NO.		枚数 SHEET	3 / 3		
日付 DATE				改訂 REV.			
符号 MARK							